

Zorita Internals Research Project EPRI

Jose Delgado
Southern Europe Country Mgr.

Asamblea General CEIDEN
Madrid October 2015



Zorita Internals Research Project (ZIRP)

Objective: Characterize the effects of neutron irradiation on the mechanical and microscopic properties of stainless steel materials irradiated under service conditions to increase the understanding of fluence effects at end of service life (40, 60 years and beyond)



Jose Cabrera NPP “Zorita”

Westinghouse design

Years of Operation 1968 – 2006 (~26 EFPY)

Participants

- EPRI
- U.S. NRC
- CSN
- SSM
- Tractebel
- AXPO
- Additional in-kind contribution from Japanese utilities/MHI

Zorita Internals Research Project

Material Retrieval and Shipping



On-Site Challenges

- Decommissioning activities were top priority
- Retrieval activities could not impact critical path
- Highly-active materials required special handling and equipment
- On-site coordinator was essential and valuable

Shipping Challenges

- Highly-active materials required fuel-type shipping container
- Changes to shipping dates needed to be accommodated
- Approvals required from numerous authorities in multiple countries



Zorita Internals Research Project

Cutting Plan – Baffle Plates

- Baffle plate material between 3rd and 4th formers
- Type 304 Stainless Steel
- Doses ranging from a few dpa to ~50 dpa
- Thickness 28.6 mm

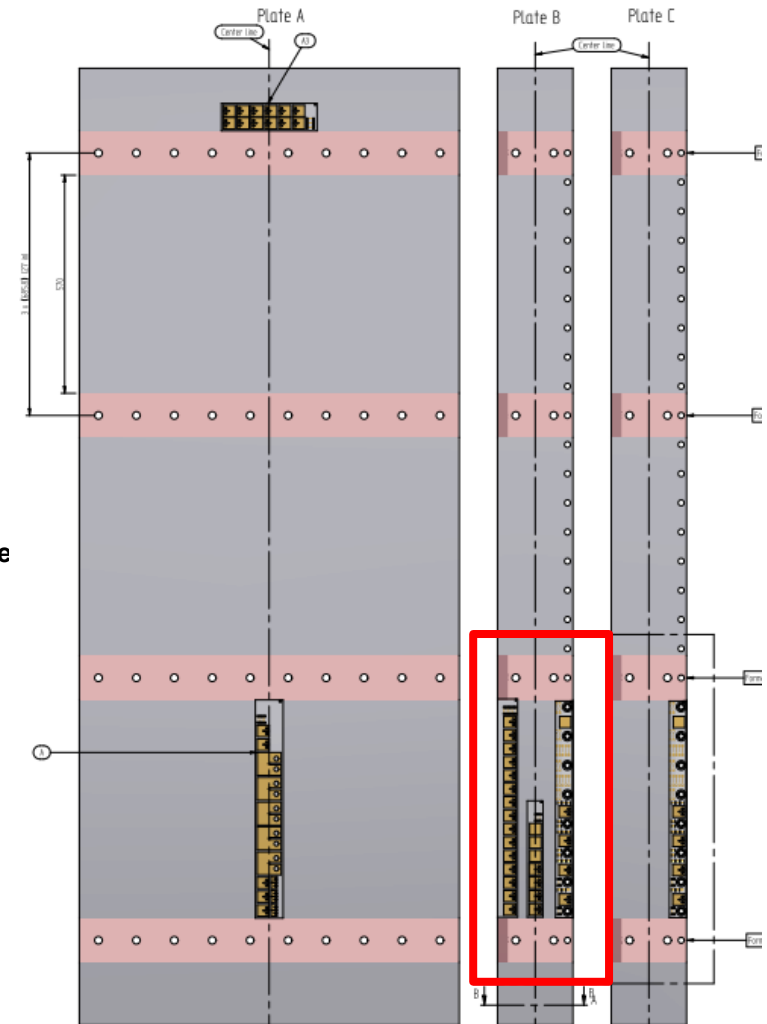
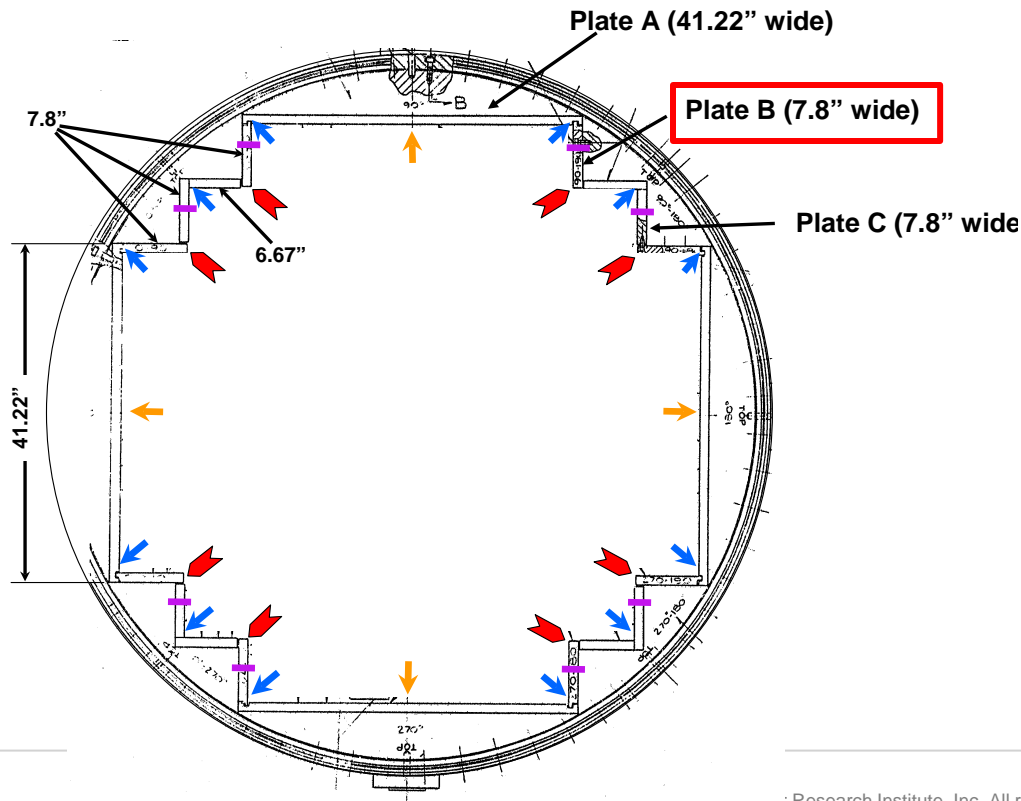

Zorita Internals Research Project

As-Received Materials

B3



B2



B1



Part: LI-baffle-plate-sw0041

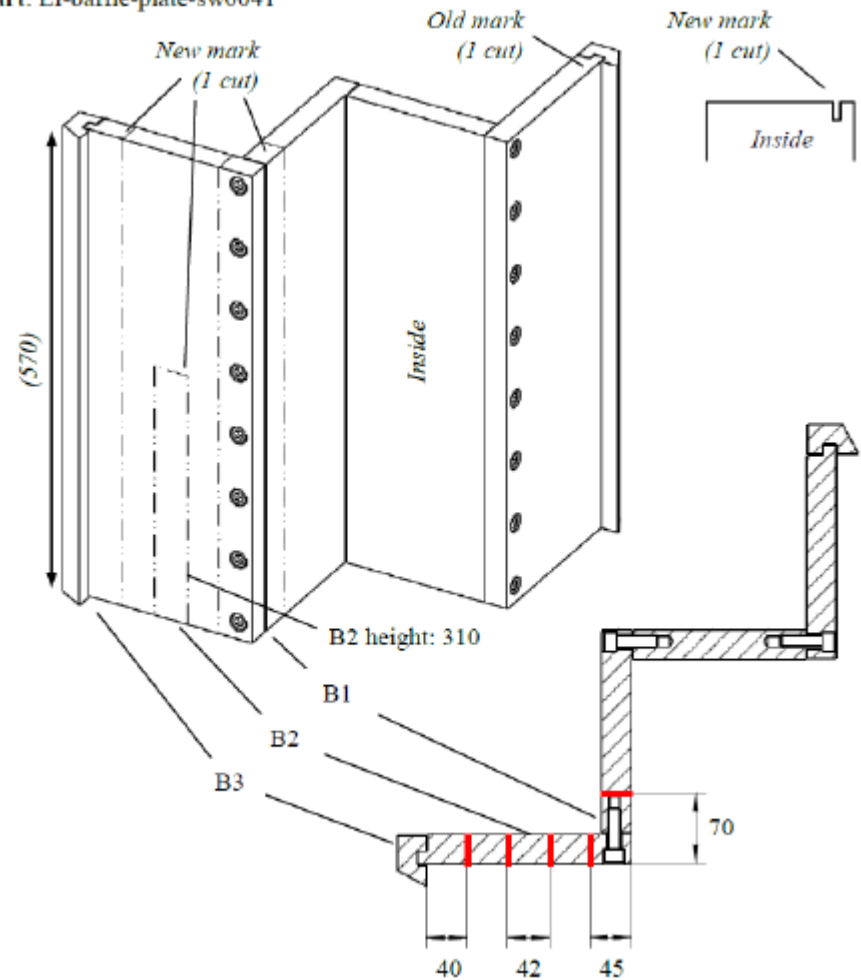

Zorita Internals Research Project

Testing Plan

Property	Dose (dpa)	Schedule	Notes
Tensile Testing	10, 30, 50	2014	Completed: each dose at room temperature and 320 °C
IASCC Crack Initiation	50	2014-2016	Underway: O-ring and UCL specimens; test duration 9,000 hours
IASCC Crack Growth Rate	10, 30, 50	2014-2015	Underway: Each specimen tested at 3 temperatures and 2 K_I levels; 1 specimen at each dose complete
Fracture Toughness	10, 30, 50	2014-2015	Underway: 10 dpa specimens in air complete; tests in primary coolant (10 dpa) to begin in 2015; 30 and 50 dpa specimens to follow
Microstructural Testing	32 to 47	2015-2016	Underway: Specimen material sent to Japan for testing including void swelling characterization, gas analysis (He, H), microhardness, optical microscopy

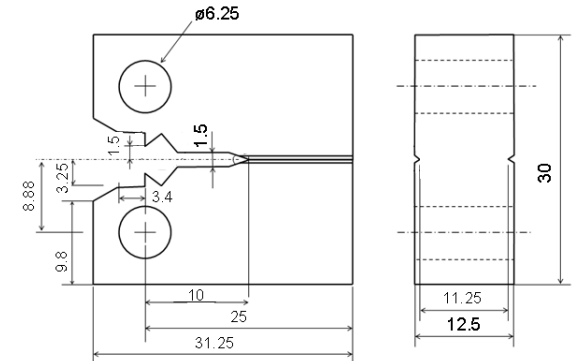
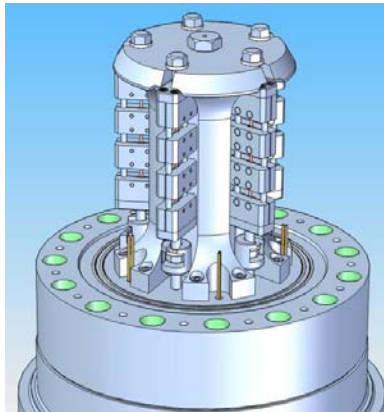
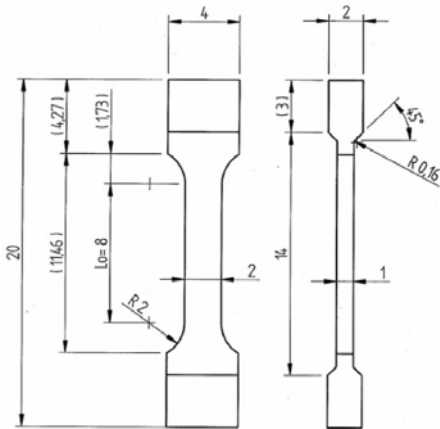

Zorita Internals Research Project

Project Timeline

- Extensive effort on the front end of the project
- Testing represents a small portion of the project timing
- Zorita project will provide test results well ahead of other proposed decommissioning efforts
 - Results will contribute to aging management programs for operation beyond 40 years

Task	2007	2008	2009	2010	2011	2012	2013	2014	2015	2016
Project Inception	★									
Feasibility Study										
Project Planning Cutting Plans Equipment Design & Manufacturing On-site Preparations										
Material Extraction On-site Logistics Shipping										
Radiation and Temperature Analyses										
Material Inspection, Inventory, Documentation										
Materials Testing										
Reporting										

